

Structure of DNA and RNA

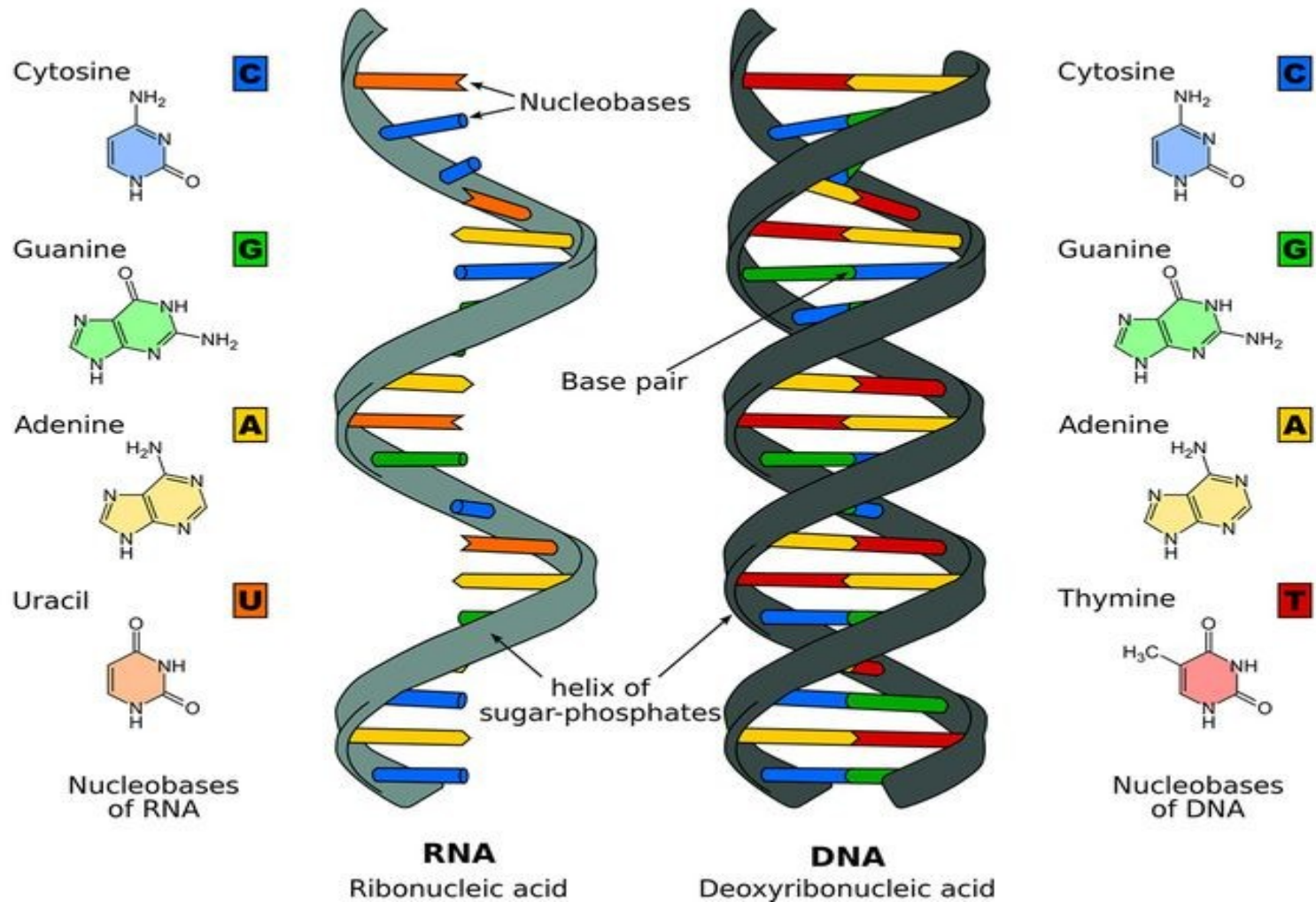

WARM UP:

Look over the images below and create a list of similarities and differences that you find. YOU MUST HAVE AT LEAST THREE OF EACH.

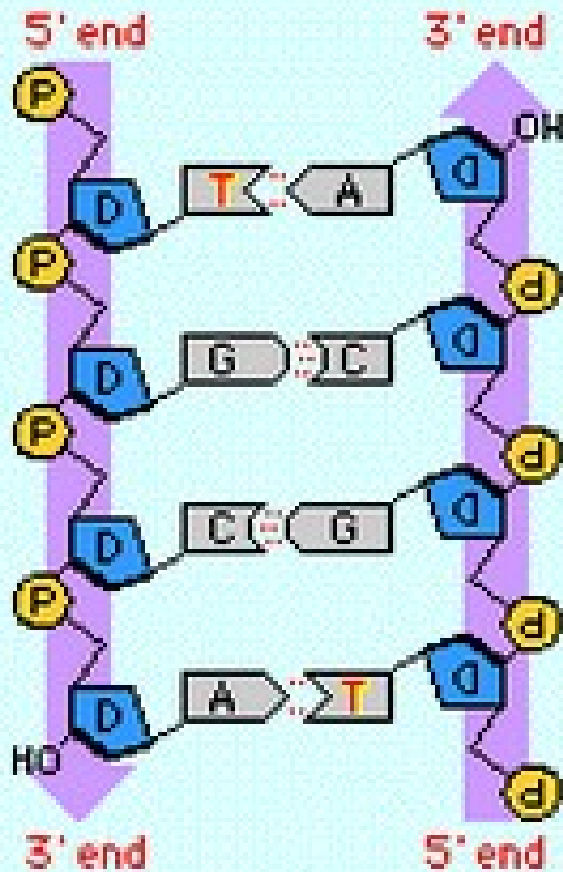

Polynucleotides

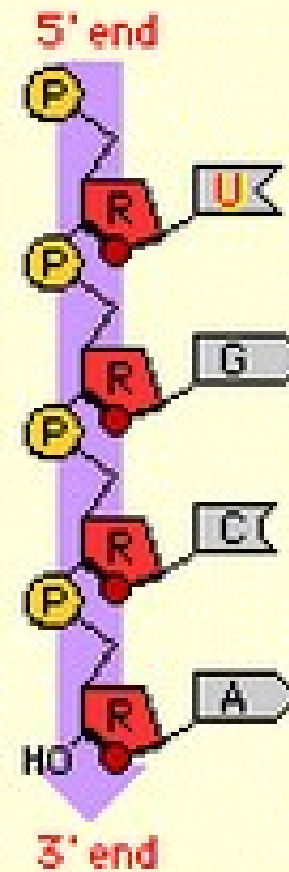

SIMILARITIES

DIFFERENCES

DNA vs. RNA STRUCTURE AND FUNCTION



Deoxyribonucleic Acid

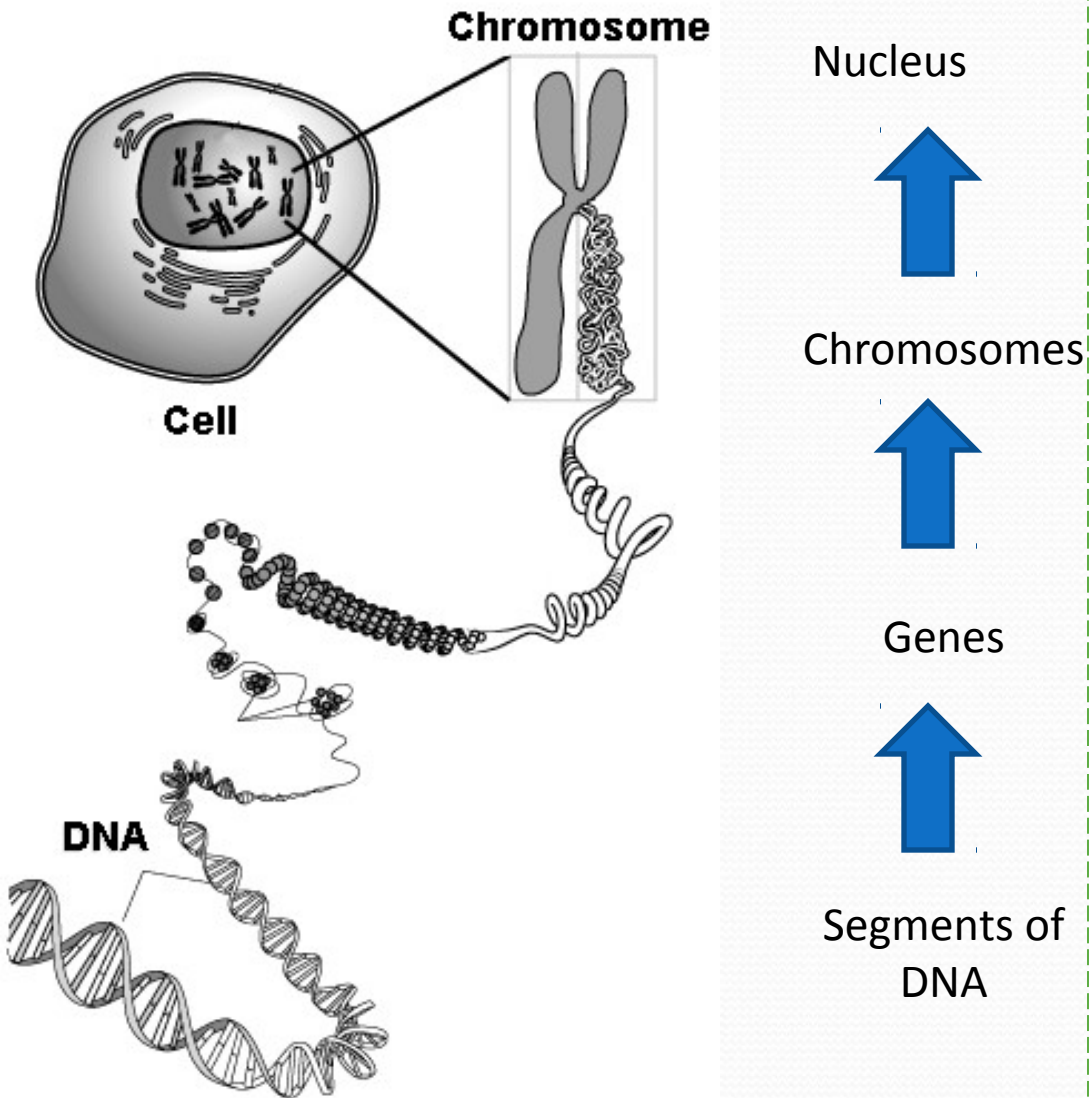

Portions of DNA are called genes.

DNA is tightly wound into chromosomes and located in the nucleus of cells.

DNA cannot leave the nucleus.

DNA is **DOUBLE STRANDED**(2 sides)

Ribonucleic Acid

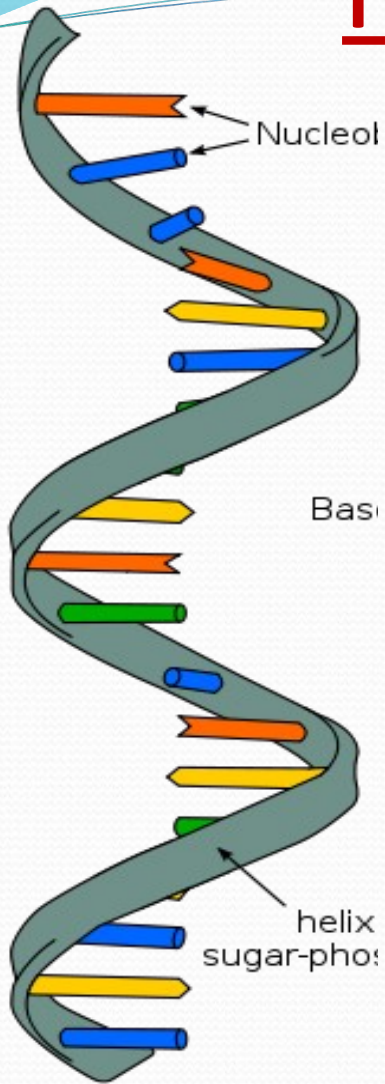

RNA

Ribonucleic acid

RNA is **SINGLE STRANDED** and does not have to stay in the nucleus!

RNA is not found in chromosomes because it does not carry the genetic code, however it can read the **DNA code and take the information out of the nucleus.**

RNA's main job is to build proteins!

DNA Structure

- The building blocks of DNA are called Nucleotides.
- One nucleotide is made of 3 important things:
 1. 5-Carbon Sugar Deoxyribose
 2. Phosphate
 3. Nitrogen base

there are 4 nitrogen bases in DNA: Adenine, Guanine, Cytosine, and Thymine that pair together)

A → T

C → G

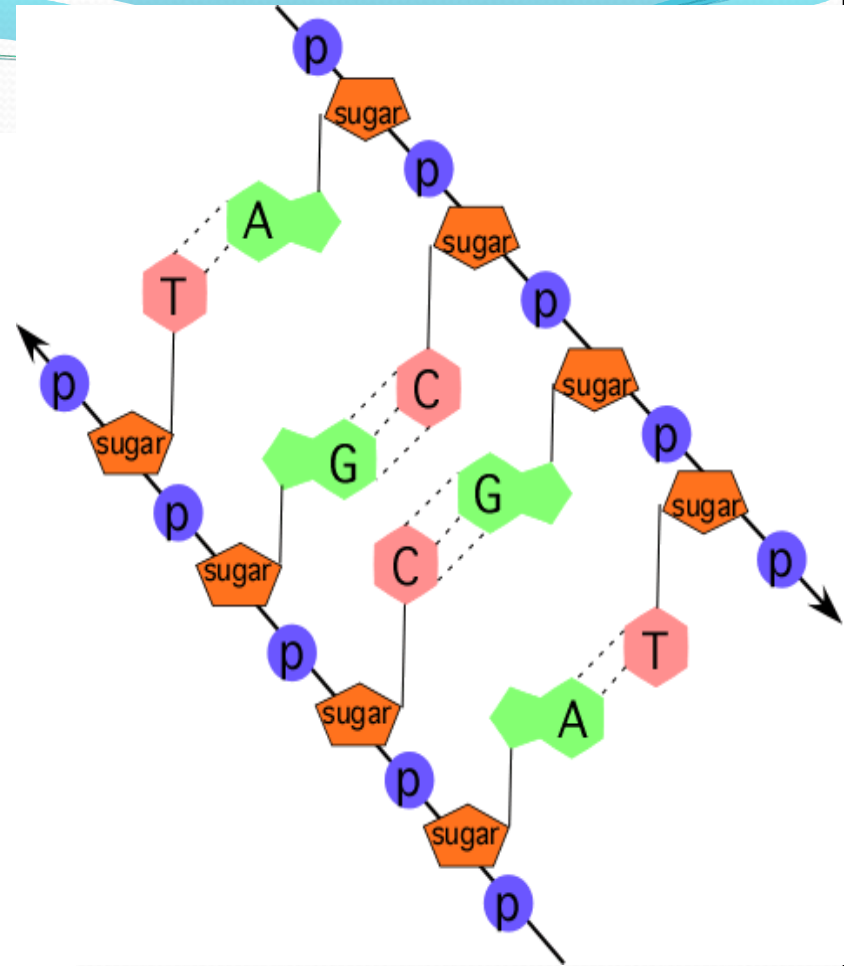

RNA Structure

- The building blocks of RNA are Nucleotides, just like DNA.
- A Nucleotide in RNA is still made of 3 important things:
 1. 6-Carbon Sugar - **Ribose** (instead of Deoxyribose)
 2. Phosphate
 3. Nitrogen base

there are 4 nitrogen bases in RNA,
A,G,C, and U that pair together)

A → U

C → G

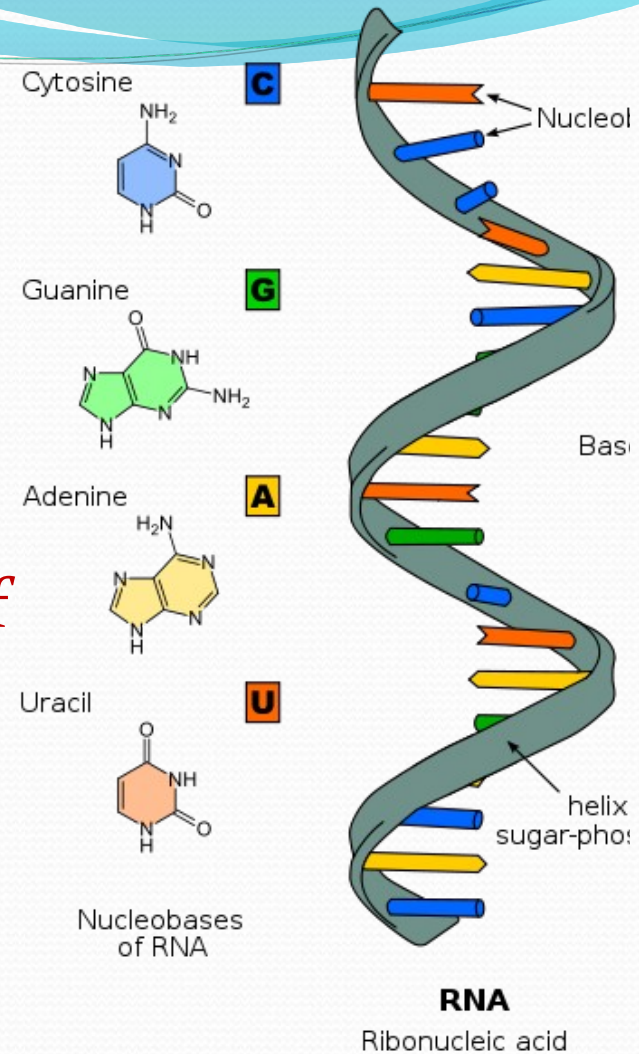

DNA

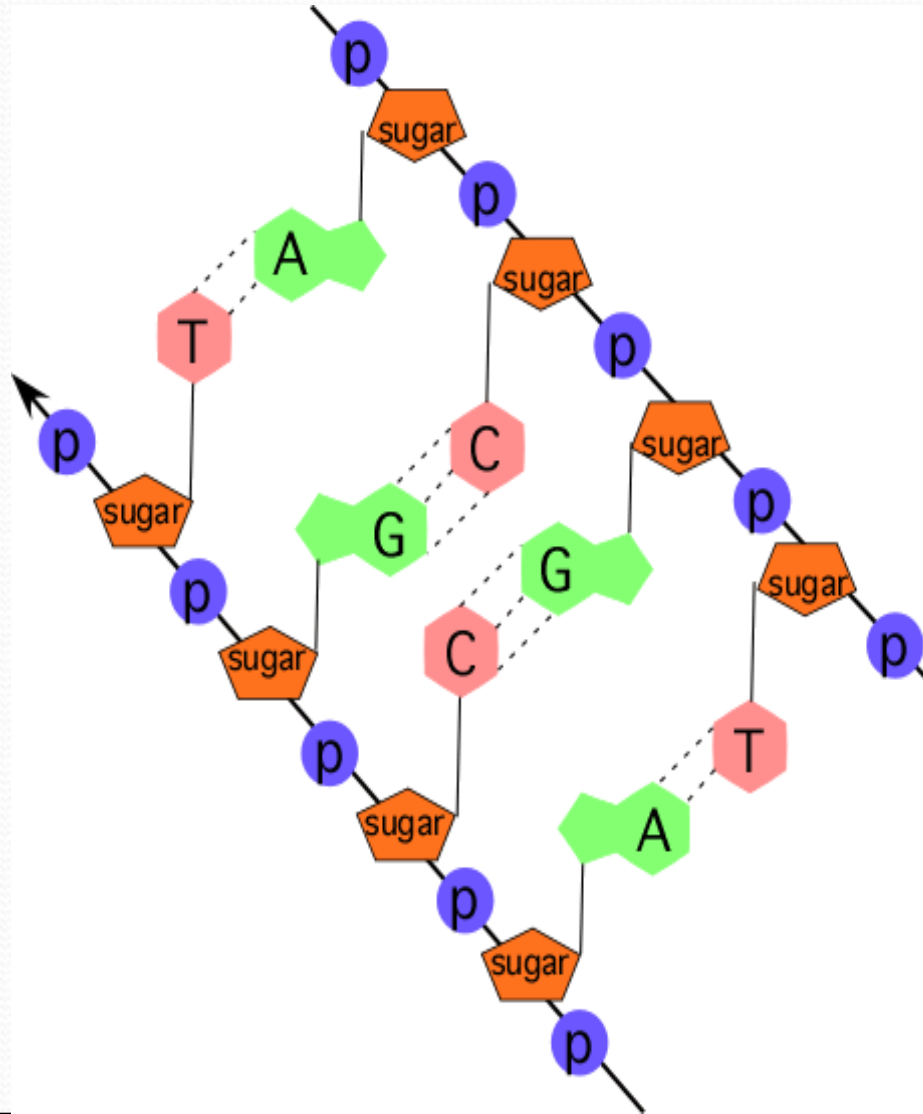

RNA

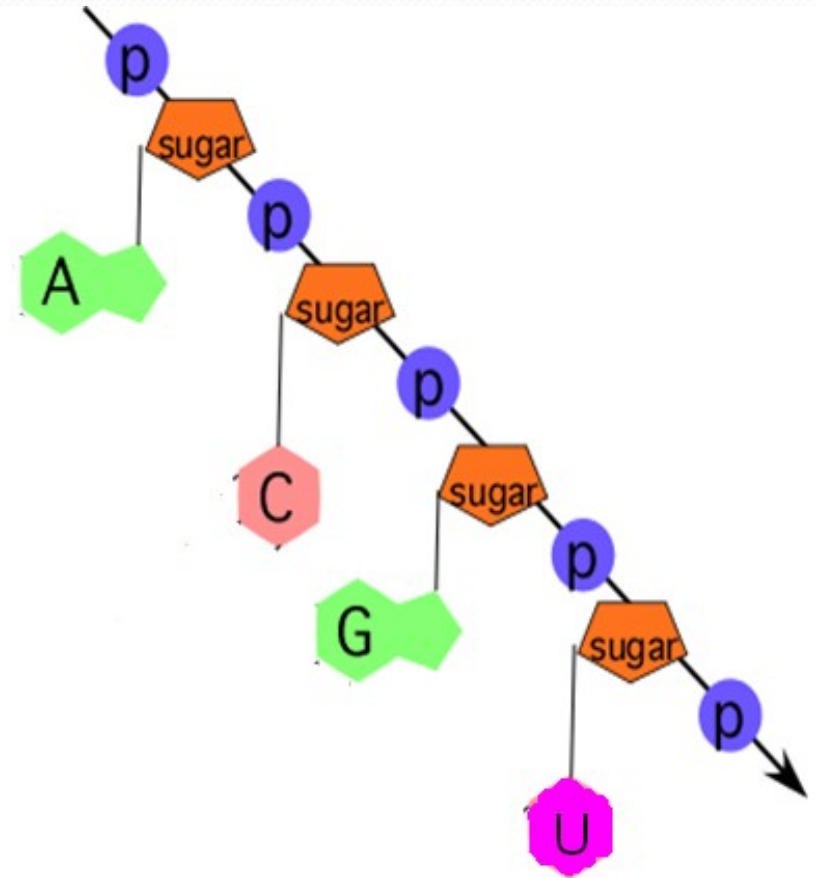

Both DNA and RNA:

a. are single stranded

b. contain the same four nitrogenous bases

c. have the same five carbon sugars

d. contain phosphate groups

DNA

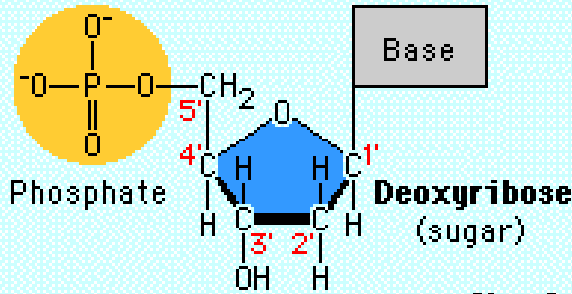

RNA

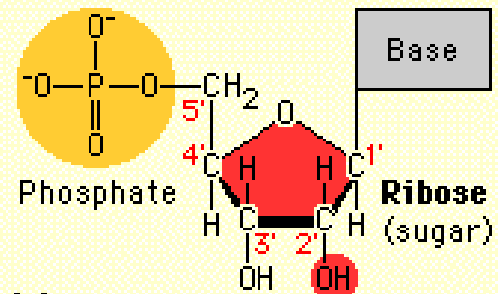

Nucleotides

Pyrimidines



Purines



Bases

Pyrimidines



Purines

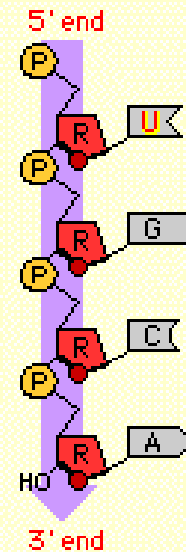
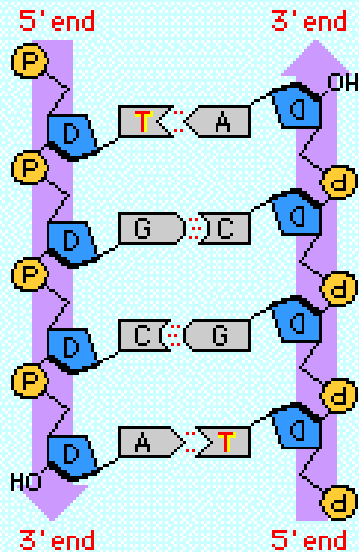

Cytosine

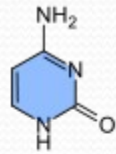

C

Guanine

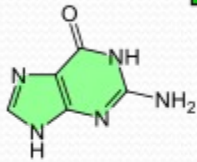

G

Adenine

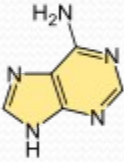

A

Uracil

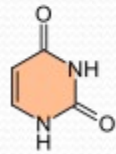

U

Nucleobases
of RNA

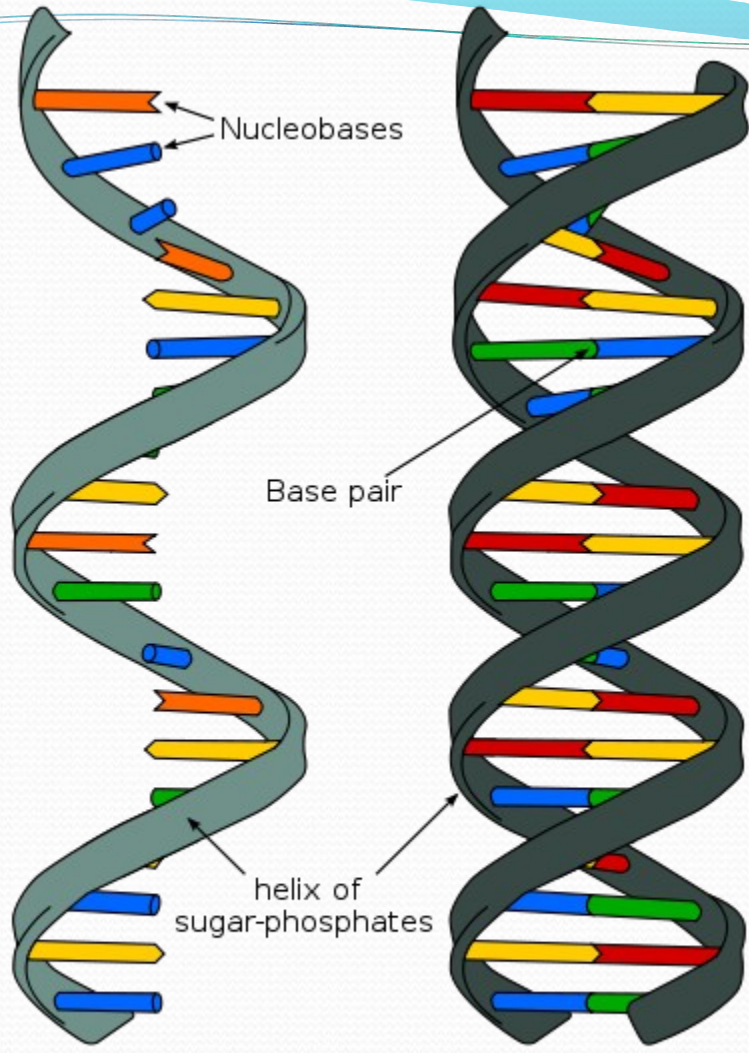

RNA

Ribonucleic acid

DNA

Deoxyribonucleic acid

Cytosine

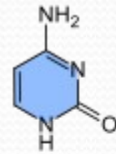

C

Guanine

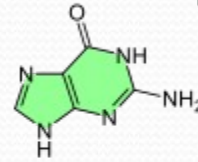

G

Adenine

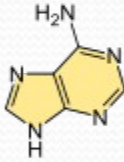

A

Thymine

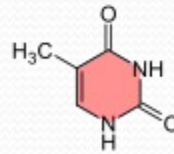

T

Nucleobases
of DNA

Three Main Types of RNA

1. Messenger RNA (mRNA) - Carries copies of instructions for the assembly of amino acids into proteins from DNA to the rest of the cell (serve as “messenger”)

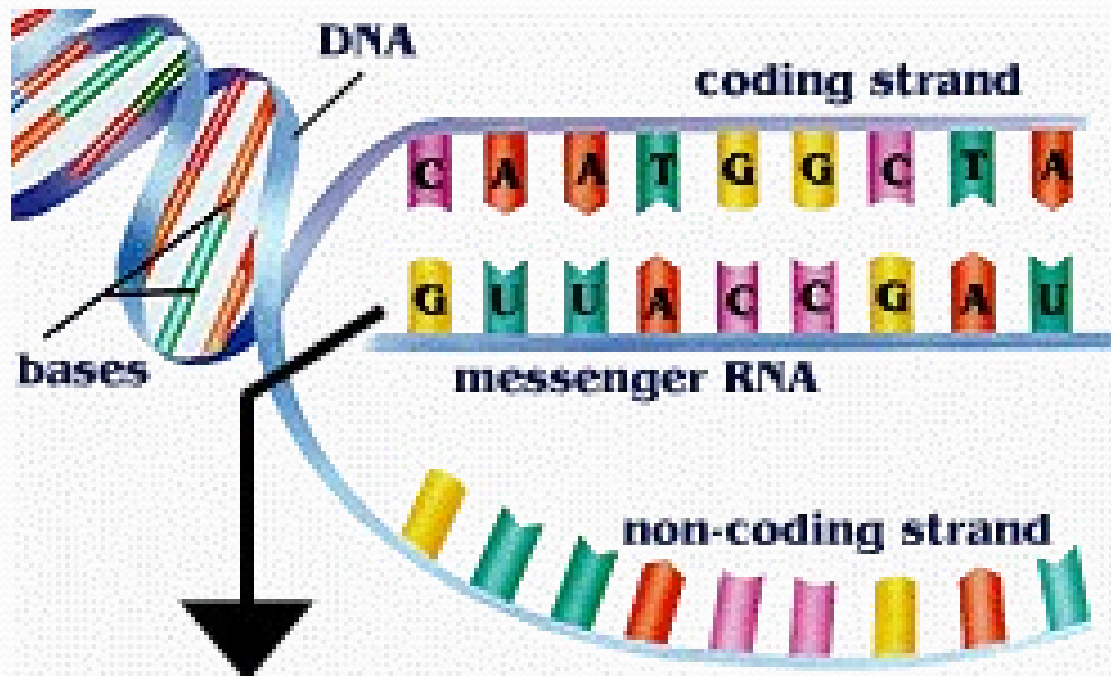

Three Main Types of RNA

2. Ribosomal RNA (rRNA) – Makes up the major part of ribosomes, which is where proteins are made.

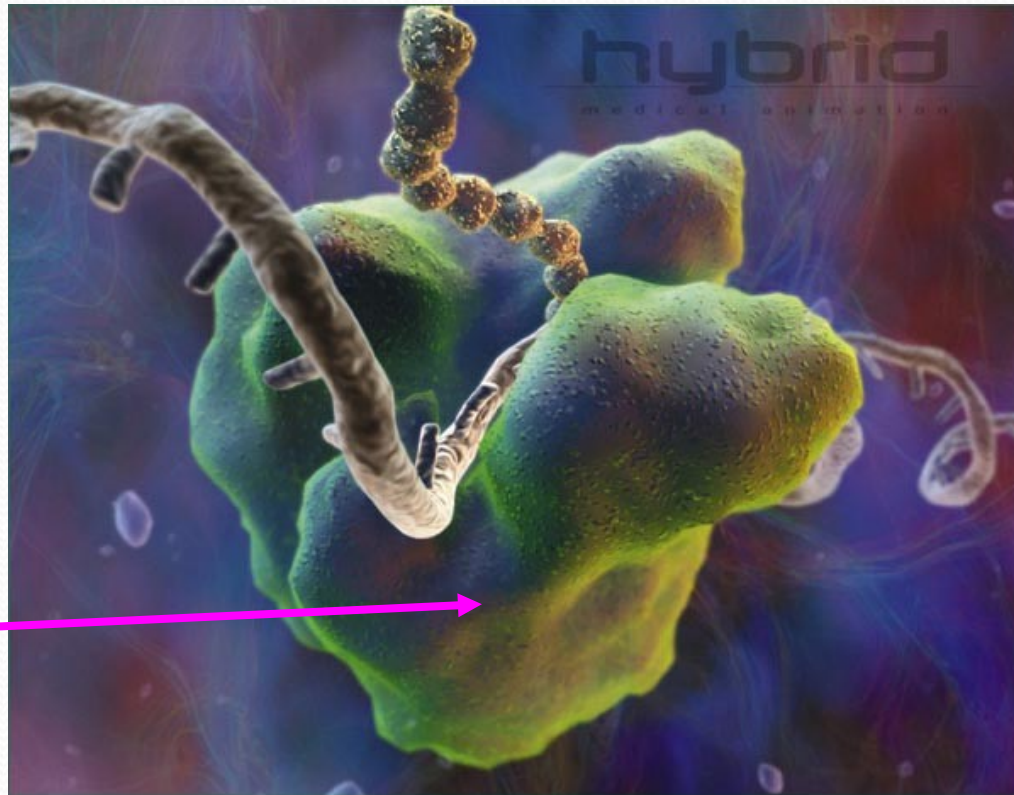

**Ribosomal
RNA**

Three Main Types of RNA

3. Transfer RNA (tRNA) - Transfers amino acids to ribosomes during protein synthesis

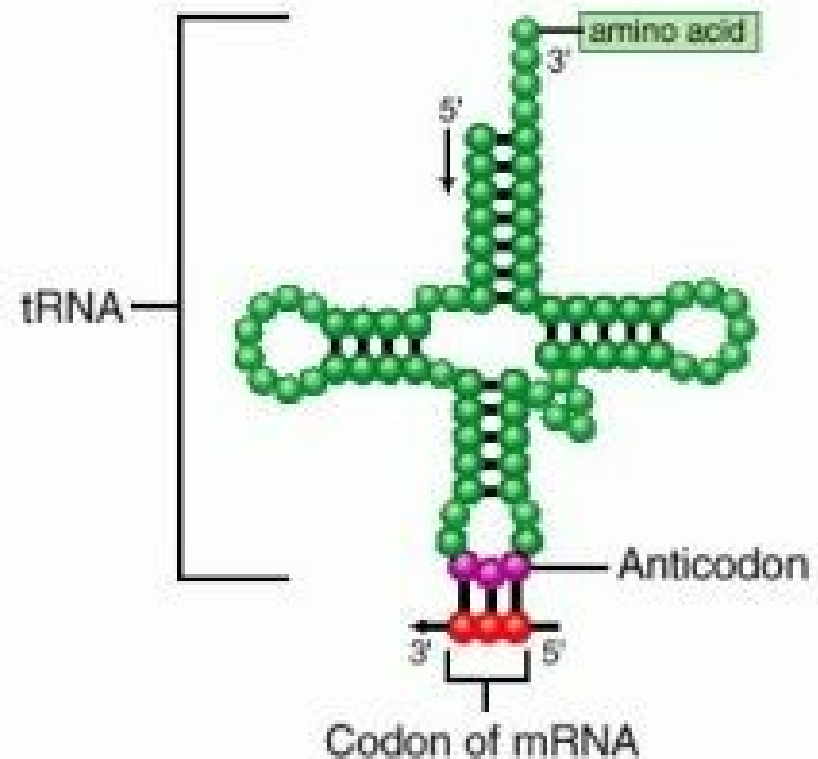
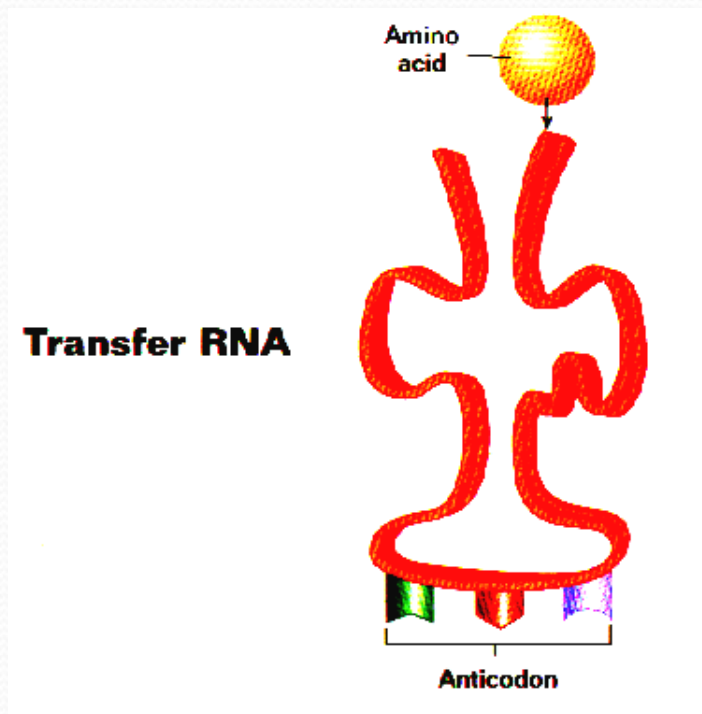

Proteins

- Proteins are made up of a chain of amino acids.
- Proteins are enzymes, which catalyze and regulate chemical reactions.

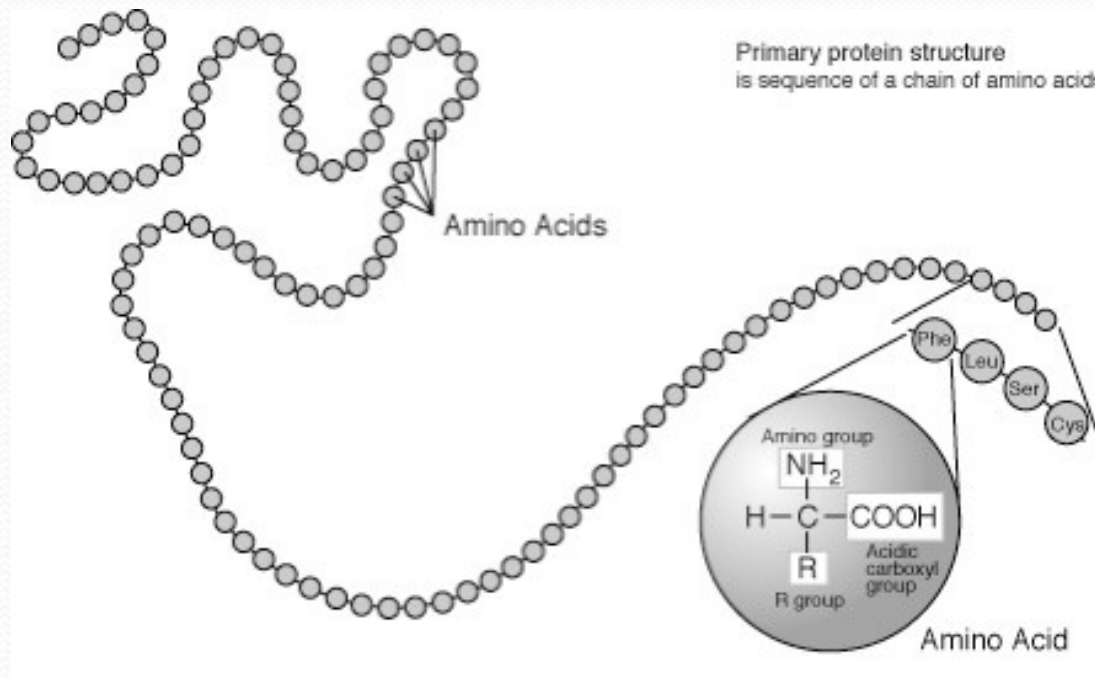

- When transcription needs to take place, DNA must provide the code in order to create an mRNA strand.
- mRNA will be able to leave the nucleus and now it has the code transcribed inside it's base pairs!

- Practice:

DNA strand: TTA ACG GGT CTA

Matching DNA strand: AAT TGC CCA GAT

mRNA: UUA ACG GGU CUA

A segment of DNA has one strand with the following sequence of bases:

AGC GCA TAG CAA

The complimentary strand of RNA would be

- a. UCG CGU AUC GUU
- b. TCG CGT ATC GTT
- c. AGC GCA UAG CAA
- d. CTA TAC GCT ACC